

ICC TRI-CHAPTER UNIFORM CODE COMMITTEE (TUCC)



POLICY NUMBER: 11

APPROVAL DATE: November 6, 2008

1st REVISION DATE: July 8, 2010 (Electrical Diagram)

2nd REVISION DATE: April 14, 2011

SUBJECT: Residential (Single-Family) Roof Mounted Solar Photovoltaic System Utility Grid - Tie Connection

This guideline is developed by the Tri-chapter Uniform Code Committee and is intended to enhance regional consistency in application and enforcement of the Building Code. Please verify acceptance of this guideline with your local building department prior to its application.

CODE REFERENCE (S):

2010 California Electrical Code Article 690 Solar Photovoltaic Systems

ISSUE (S):

There is a substantial increase in the number of solar photovoltaic system installations because of the California Solar Initiative and the Governor's support for solar energy. However, the permitting process for these systems is not consistent among jurisdictions. Often times, the submitted plans are incomplete and thus delay permit issuance. This guideline will promote uniformity of solar photovoltaic plans in our region and help expedite permit issuance.

PROPOSED GUIDELINE:

Plans submitted for a permit must contain the following items:

- 1) Plan view showing location of the PV installation and layout of existing roof framing members that support the system;
- 2) Details on mounting of PV modules, type and number of roof coverings, and subsequent weatherproofing of the roof;
- 3) Electrical single-line diagram clearly identifying all devices installed in the PV system and indicating total kVA rating of system;

- 4) Clearly identify the point of interconnection with the utility supplied wiring system and provide details on main breaker, PV breaker and rating of bussing;
- 5) Indicate type and size of all conduit and conductors throughout the PV system;
- 6) Provide manufacturer's cut-sheets and installation instructions for all PV modules, mounting systems, combiner boxes (if used), inverters, and disconnects;
- 7) Provide structural calculations, prepared by a registered California design professional, if the total weight of the photovoltaic system is over five pounds per square foot;
- 8) The installation of the PV system shall conform to the requirements of CEC Article 690 and any other applicable articles or standards.

A sample of the plan view and electrical one-line diagram pages are attached.

PV ARRAY LAYOUT & WIRING PLAN

MOUNTING NOTES

1. PANELS MOUNTED ON ALUMINUM RACKING
2. PV ARRAY MOUNTS TO ROOF STRUCTURE WITH $\frac{5}{8}$ " LAGS EMBEDDED 2 $\frac{1}{2}$ " INTO RAFTERS OR SEE NOTE 5 BELOW
3. PV PANELS ARE ANCHORED @ 48" O.C. TRUSSES/ RAFTERS ARE 24" O.C. OR SEE NOTE 5 BELOW
4. WEIGHT OF PV MODULES AND ASSEMBLY LESS THAN 5 LBS PER SQUARE FOOT
5. ALL INSTALLATIONS MUST COMPLY WITH MANUFACTURER'S INSTALLATION INSTRUCTIONS.

ARRAY CONDUIT & WIRING ARRANGEMENT

1. FREE-AIR / $\frac{1}{2}$ " CONDUIT SLEEVE**
(2) #12 AWG; R, W
 2. TO DC DISCONNECT
1/2" CONDUIT
(4) #12 AWG: (2)R, (2)W
(1) #8 GND
- ** SLEEVE PROVIDES PROTECTION FROM PHYSICAL DAMAGE PER NEC 300.13 & 300.18

DC DISCONNECT
INVERTER
PHOTOVOLTAIC SYSTEM DISCONNECT
EXISTING SERVICE PANEL / NET METER

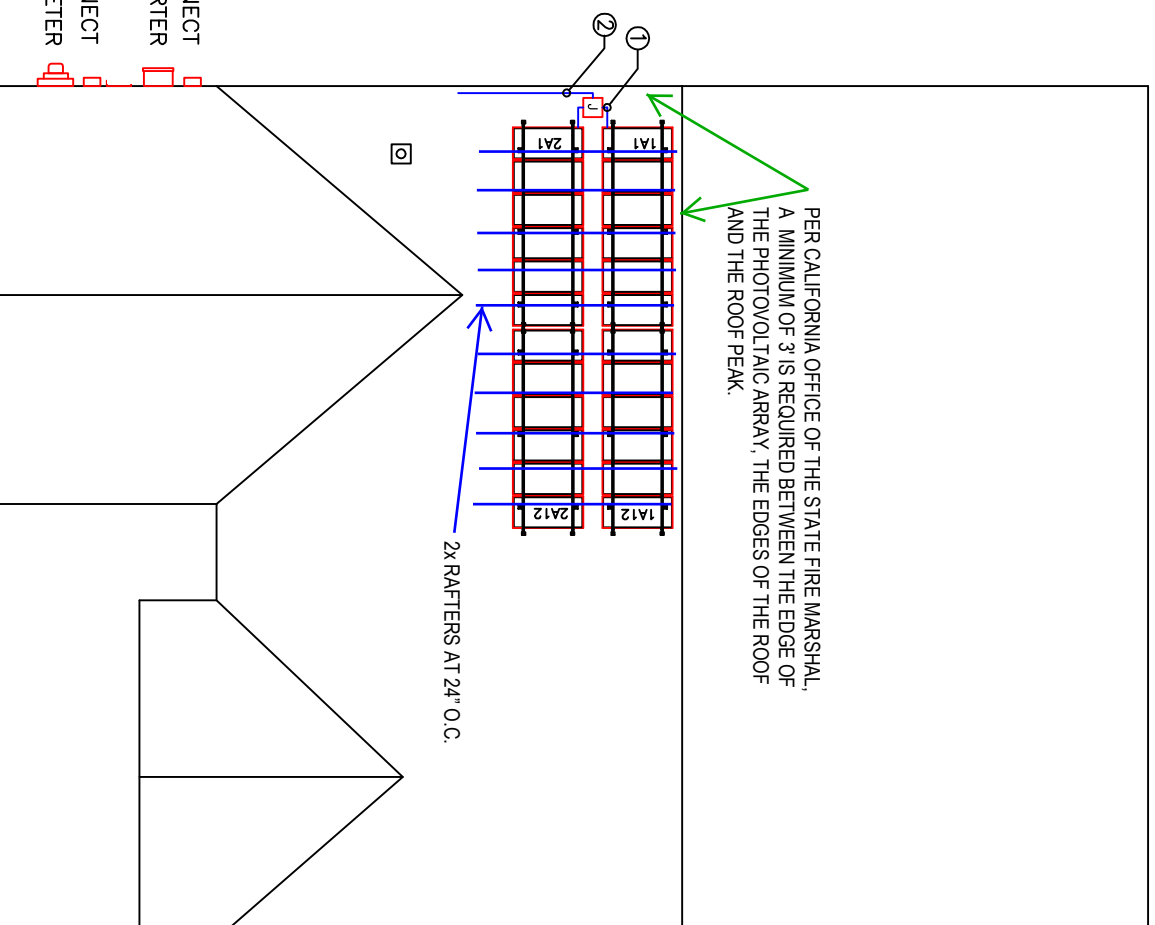

CUSTOMER NAME

ADDRESS

DRAWN BY

?

CHECKED BY

?

SCALE

NTS

DATE DRAWN

?

COMPANY
LOGO

COMPANY NAME
ADDRESS

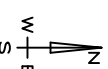

PV MODULE RATING @ STC

MODULE MANUFACTURER _____
 MODULE MODEL # _____
 MAX POWER-POINT CURRENT (I_{mp}) = _____ A
 MAX POWER-POINT VOLTAGE (V_{mp}) = _____ V
 OPEN-CIRCUIT VOLTAGE (V_{oc}) = _____ V
 SHORT-CIRCUIT CURRENT (I_{sc}) = _____ A
 MAX POWER (P_{max}) = _____ W
 MAX SYSTEM VOLTAGE = 600 Vdc
 V_{oc} TEMPERATURE COEFF. = _____

SYSTEM VOLTAGE AND CURRENT

MAX POWER-POINT CURRENT (I_{mp}) = _____ A
 MAX POWER-POINT VOLTAGE (V_{mp}) = _____ V
 OPEN-CIRCUIT VOLTAGE (V_{oc}) = _____ V
 SHORT-CIRCUIT CURRENT (I_{sc}) = _____ A

SYSTEM VOLTAGE AND CURRENT INCLUDING CORRECTION FACTORS

OPEN-CIRCUIT VOLTAGE (V_{oc}) = _____ V
 SHORT-CIRCUIT CURRENT (I_{sc}) = _____ A

INVERTER RATING

INVERTER MODEL # _____
 MAX DC VOLT RATING = _____ V
 MAX POWER @ 40°C = _____ W
 NOMINAL DC VOLTAGE = _____ V
 MAX. AC CURRENT = _____ A
 MAX OCPD RATING = _____ A

DC DISCONNECT RATING

DISCONNECT AMP RATING = _____ A
 DISCONNECT VOLT RATING = _____ V

AC DISCONNECT RATING

DISCONNECT AMP RATING = _____ A
 DISCONNECT VOLT RATING = _____ V

No. OF MODULES IN SERIES

No. OF MODULES IN SERIES

No. OF MODULES IN SERIES

ROOF TOP JUNCTION BOX
 NEMA 3R MIN. REQUIRED WITH WATERPROOF SPLICES OR OTHER APPROVED TERMINATION METHOD (NEC 110.14, 300.6, 314)

SOURCE-CIRCUIT CONDUCTOR:
 CONDUCTOR SIZE: #12 AWG MIN
 CONDUCTOR TYPE: USE-2 OR PV WIRE/CABLE

- NOTES:**
1. INSTALLER TO BE PREPARED TO PROVIDE PHYSICAL PROOF THAT PANELS INSTALLED IN FIELD MATCH THOSE SPECIFIED ON PLANS.
 2. AC & DC SIDE GROUNDING ELECTRODE CONDUCTOR TO BE BONDED PER ART. 690.47, AND MADE IN ACCORDANCE WITH ART. 250.64.
 3. BONDING JUMPER REQUIRED TO MAINTAIN CONTINUITY BETWEEN SOURCE OF OUTPUT CIRCUIT GROUNDING CONDUCTOR WHILE PV EQUIPMENT IS REMOVED PER ART. 690.49.
 4. PROVIDE SYSTEM LABELS AND WARNING FOR DC DISCONNECT, AC DISCONNECT AND INVERTER. LABELS TO BE AFFIXED PRIOR TO FINAL INSPECTION.
 5. ALL SYSTEMS INCLUDING SUPPORT FRAME SHALL BE GROUNDED IN ACCORDANCE WITH ART. 690.43. EQUIPMENT GROUNDING CONDUCTORS FOR PHOTOVOLTAIC MODULE SMALLER THAN A #6 SHALL COMPLY WITH ART. 250.120(C)

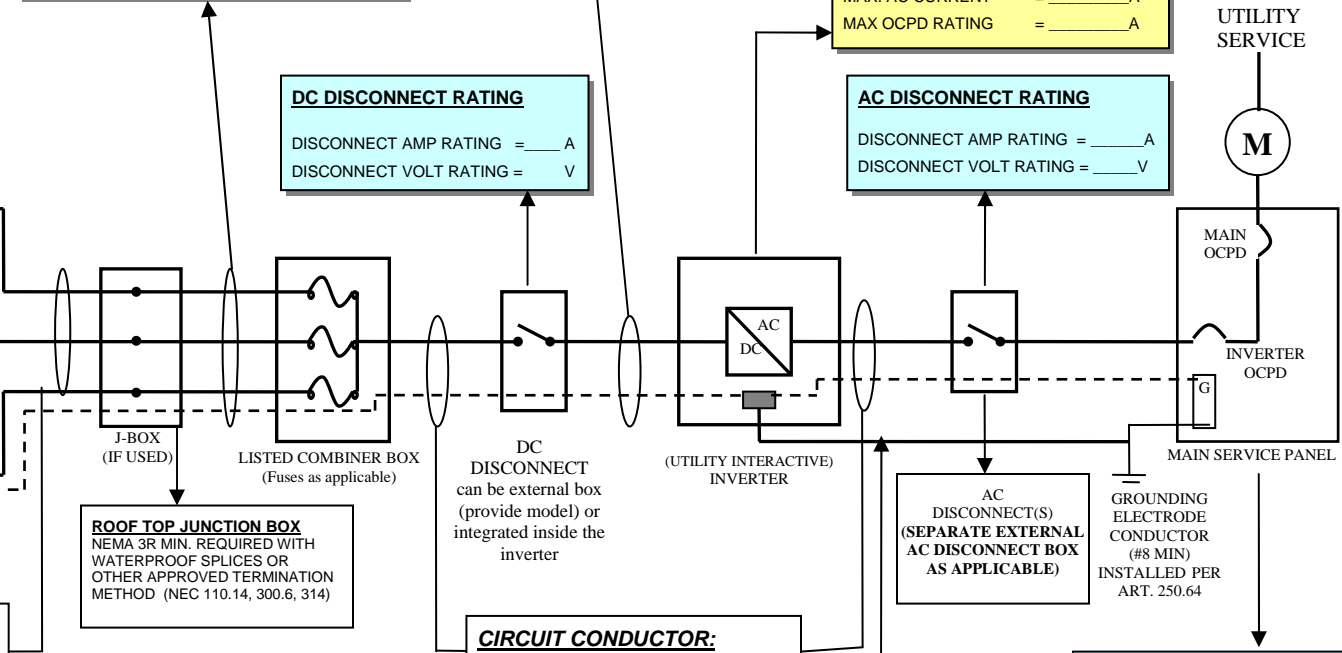

CIRCUIT CONDUCTOR:
 CONDUIT SIZE AND TYPE: 1/2" Ø MIN EMT
 CONDUCTOR TYPE: THWN-2, XHHW-2, OR RHW-2
 NUMBER OF CONDUCTOR:
 (___ Red, ___ White, 1 Green)

AC DISCONNECT(S)
 (SEPARATE EXTERNAL AC DISCONNECT BOX AS APPLICABLE)

DC GROUNDING ELECTRODE CONDUCTOR SIZE #8 AWG MIN

SERVICE PANEL RATING

BUS AMP RATING = _____ A
 SERVICE VOLTAGE = _____ V
 MAIN OCPD RATING = _____ A
 INVERTER OCPD RATING = _____ A

Notes:

1. For each inverter, supply breakers shall comply with 120% BUSBAR exception in 690.64(B)(2)(a)
2. Supply side connection is not allowed

STANDARD ELECTRICAL DIAGRAM FOR SMALL SCALE, SINGLE-PHASE PV SYSTEMS